

ST2 Coffee Guardian Specifications

dimensions in mm

SIDE VIEW

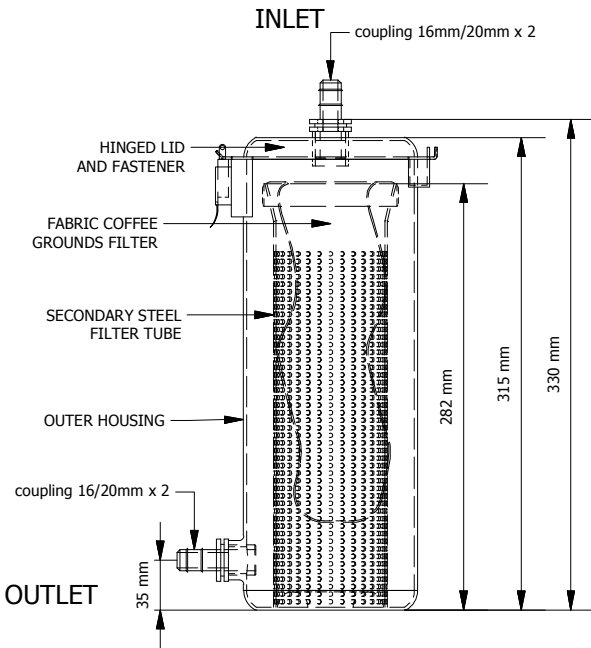

TOP VIEW

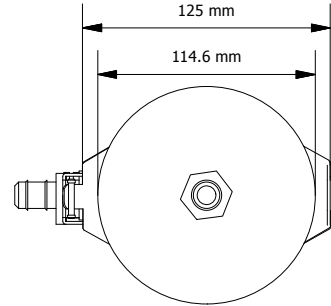

PRODUCT CHARACTERISTICS			
	HOUSING	FABRIC FILTER	METAL FILTER
MATERIAL	STAINLESS STEEL, 16 GAUGE	NYLON	STAINLESS STEEL 16 GAUGE
CAPACITY	2.7 LITRES	1 KG	1 KG

INSTALLATION ADVICE

ST2 SYSTEM SHOULD BE POSITIONED IN THE CABINET BENEATH THE COFFEE MACHINE USING TWO BRACKETS PROVIDED. OBSERVE THE FOLLOWING:

POSITIONING:

- ENSURE CLEARANCE IS PROVIDED FOR OPENING OF HINGED LID AS INDICATED HERE.
- ENSURE SYSTEM IS PLACED CLOSE TO THE FRONT OF CABINET FOR EASY INSPECTION AND ACCESS.

USE THE EXISTING COFFEE MACHINES FLEXIBLE WASTE HOSE TO CONNECT THE ST2 INLET TO THE COFFEE MACHINE WASTE OUTLET ABOVE. SIMILARLY CONNECT THE ST 2 OUTLET TO FLOOR WASTEPOINT.

ENSURE A GRAVITY FALL IS MAINTAINED FROM THE ST2 OUTLET TO DRAIN

THIS SYSTEM INCLUDES BOTH 16 AND 20 MM HOSECONNECTORS FOR MOST CONNECTION TYPES

MAINTENANCE NOTES:

FABRIC FILTER CAN BE REPLACED REGULARLY WITHOUT NEED TO REMOVE THE INTERNAL STEEL FILTER

REPLACEMENT FREQUENCY GUIDE FOR 1KG CAPACITY FABRIC FILTER
 1 CUP OF COFFEE = 0.1gr WASTE
 100 X CUPS/DAY = 10gr.
 OR 100 DAYS FILTER CAPACITY
VALUES MAY VARY DEPENDING ON COFFEE BRAND AND MACHINE TYPE

TO PERIODICALLY REMOVE AND CHECK THE SECONDARY STEEL FILTER, OR TO CLEAN INSIDE THE MAIN HOUSING, THE ST2 UNIT CAN BE COMPLETELY UNCLIPPED FROM THE TWO WALL BRACKETS SHOWN.

TYPICAL INSTALLATION

